



NEW



DECENTRALISED HEAT RECOVERY UNIT

APPLICATION

Decentralised Mechanical Ventilation unit, with alternate flow and heat recovery core ("push-pull" type): extremely low energy consumption.

For installation in single room such as living room and bedroom: for a better flow balancing two units are commonly used in parallel operation, having opposite and synchronised flows.

SPECIFICATIONS

Internal ventilation unit and wall base made of high quality ABS providing long lasting shockproof and robust construction. Finished in white RAL 9010 and UV resistant.

Infra-red remote controller with touch technology and wall base supplied as standard. Made from ABS, RAL 9010.

Unique design winglet-type impeller, providing enhanced aerodynamic properties, low noise and increased efficiency.

High efficient reversible EC motor with integral thermal protection, mounted on sealed for life high quality ball bearings. Designed for continuous running.

Regenerative heat exchanger with ceramic core with high thermal efficiency.

Washable anti-dust filters, on each side of the heat exchanger.

Telescopic pipe made from 100% recycled ABS, adaptable to the wall thickness.

External grille with anti-insect net and water drip guard.

FEATURES & BENEFITS

IPX4 protection degree.

Aesthetic flat front cover for modern interior design, easily removable for cleaning without the need of tools.

Multifunction remote controller, with LCD display to visualise the status of the unit.

Back-up touch button at the side of the ventilation unit.

Automatic management of the inversion time (comfort mode) to optimise the acoustic and thermal comfort.

Integrated multi-colour led to obtain a visual feedback of the unit status.

Smart humidity control.

Free cooling: extract only or intake only to prevent heat exchange when not needed.

Simplified synchronisation of more units (up to 10): thanks to a dedicated communication protocol the units get automatically synchronised when they are wired each other.

Easy and safe maintenance thanks to a magnet "coupling/uncoupling" system which allows the ventilation unit to be quickly removed from its base.

Automatic anti-frost protection to prevent frost building up on the heat exchanger.

No water drainage is needed.

Streamlined electrical wiring (L and N only).

Totally recyclable plastic components, environmentally friendly.

Double insulated: no earth connection is required.

Tested to the latest standards: units are tested in the TÜV Rheinland recognised laboratory at Aerauliqa, meaning accurate, up to date information on electrical safety, performance and noise level that can be relied upon. Designed and manufactured in accordance with EN60335-2-80 (Low Voltage Directive) and the EMC Directive (Electromagnetic Compatibility).

MODBUS CONNECTIVITY

The units are equipped with a Modbus communication module that allows interfacing with the CTRL-HO centralised control panel, thus creating a **decentralised units system with heat recovery capable of ventilating the entire house.**

Orion

Example of a complete ventilation system

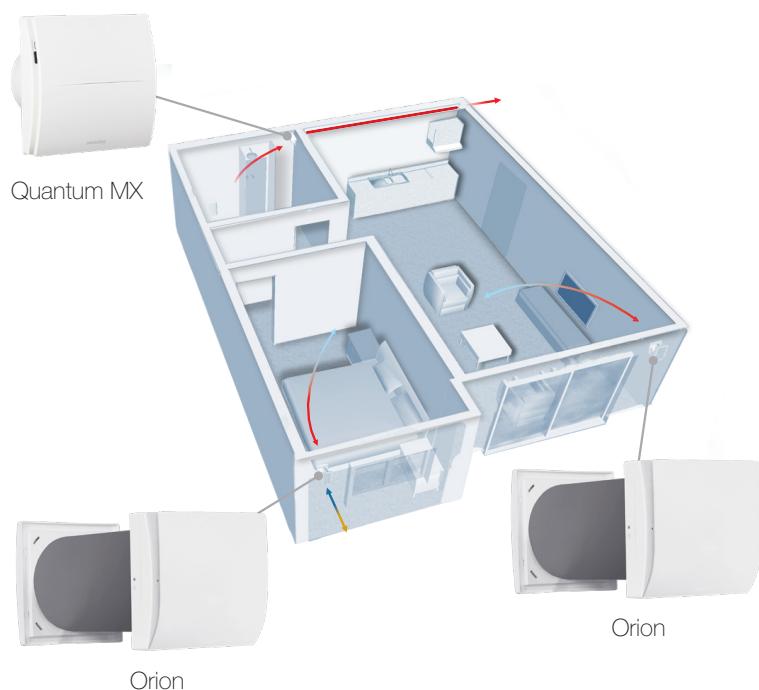

Application: ideal solution in case of renovation.

How it works: the continuous running decentralised heat recovery units (Orion) transfer thermal energy from air extracted from indoor rooms to incoming fresh air. Two units can work synchronised with balanced air flows and top acoustic comfort and can be controlled through the same IR controller.

The system can also include a single flow decentralised unit (Quantum MX) mounted in the wet room. No air distribution system is needed.

Energy saving: the preheated supplied fresh air and continuous air changes reduce the demand for additional heating. Orion and Quantum MX are equipped with EC brushless motors which significantly reduce the electricity consumption.

Indoor Air Quality: a correctly specified mechanical ventilation system can ensure the quality of the indoor air is constantly maintained for the health and well-being of the occupants as well as of the building. Duly maintained filters on Orion ensure that incoming air is suitably filtered before it enters the home.

Dimensions (mm) and Weight (kg)

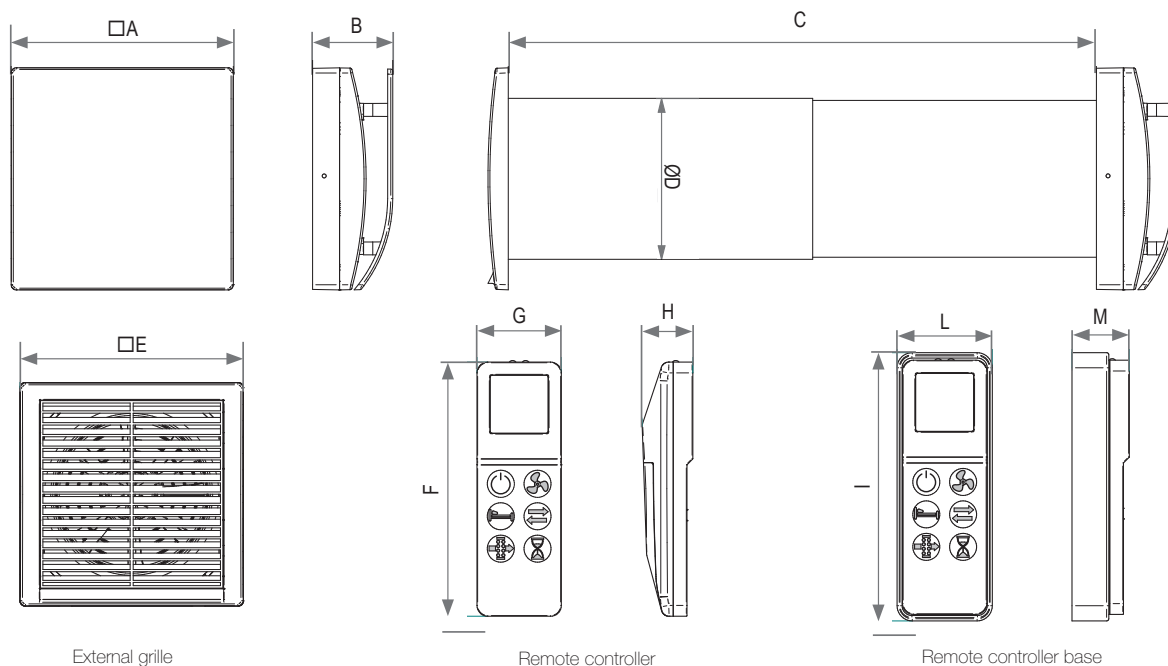

Model	□A	B	C	∅D	□E	F	G	H	I	L	M	Weight
Orion 100	218	79	300÷570	110	164	117,5	39	23	124	44	26,5	2,4
Orion 150	218	79	300÷570	159	218	117,5	39	23	124	44	26,5	4,3

Article code

Model	Orion 100	Orion 150
Code	005798	005797

Product fiche - ErP Directive, Regulations 1253/2014 - 1254/2014

a)	Mark	-	AERAULIQA	
b)	Model	-	Orion 100	Orion 150
c)	SEC class	-	A	
c1)	SEC warm climates	kWh/m ² .a	-16,6	-17,9
c2)	SEC average climates	kWh/m ² .a	-40,2	-41,5
c3)	SEC cold climates	kWh/m ² .a	-81,4	-82,7
	Energy label	-	Yes	
d)	Unit typology	-	Residential - bidirectional	
e)	Type of drive	-	Multi-speed drive	
f)	Type of Heat Recovery System	-	Heat recovery	
g)	Thermal efficiency of heat recovery	%	74	
h)	Maximum flow rate @ 0 Pa	m ³ /h	25	60
i)	Electric power input @ maximum flow rate	W	4	7
j)	Sound power level (L _{WA})	dBA	39	40
k)	Reference flow rate	m ³ /h	18	41
l)	Reference pressure difference	Pa	10	
m)	Specific power input (SPI)	W/m ³ /h	0,161	0,090
n1)	Control factor	-	0,65	
n2)	Control typology	-	Local demand control	
o1)	Maximum internal leakage rate	%	N/A	
o2)	Maximum external leakage rate	%	1	
p1)	Internal mixing rate	%	N/A	
p2)	External mixing rate	%	N/A	
q)	Visual filter warning	-	Yellow led	
r)	Instructions to install regulated grilles	-	N/A	
s)	Internet address for pre/disassembly instructions	-	www.aerauliqa.com	
t)	Airflow sensitivity to pressure variations	%	N/A	
u)	Indoor/outdoor air tightness	m ³ /h	18	50
v1)	AEC - Annual electricity consumption - warm climates	kWh	1,2	0,7
v2)	AEC - Annual electricity consumption - average climates	kWh	1,2	0,7
v3)	AEC - Annual electricity consumption - cold climates	kWh	1,2	0,7
w1)	AHS - Annual heating saved - warm climates	kWh	19,5	
w2)	AHS - Annual heating saved - average climates	kWh	43,1	
w3)	AHS - Annual heating saved - cold climates	kWh	84,3	
	Air-flow at different speed	m ³ /h	25/21/17/14/10	60/50/40/30/20
	Power consumption at different speed	W	4/3,5/3/2,5/2,5	7/5/4/3/2,5
	Sound pressure @ 3m ⁽¹⁾ at different speed	dB(A)	27/23/18/14/9	29/24/20/14/10
	Thermal efficiency	%	70/72/74/78/82	
	Ambient temperature max	°C	-20°C ÷ +50°C	
	Degree of protection IP	-	X4	
	Marking/Mark	-	CE	

- 220-240V ~ 50Hz - Air performance measured according to ISO 5801 a 230V 50Hz, air density 1,2 Kg/m³.
 - data measured in the TÜV Rheinland recognised laboratory in Aerauliqa.

(1) sound pressure level @ 3m in free field, for comparative purposes only.

Details

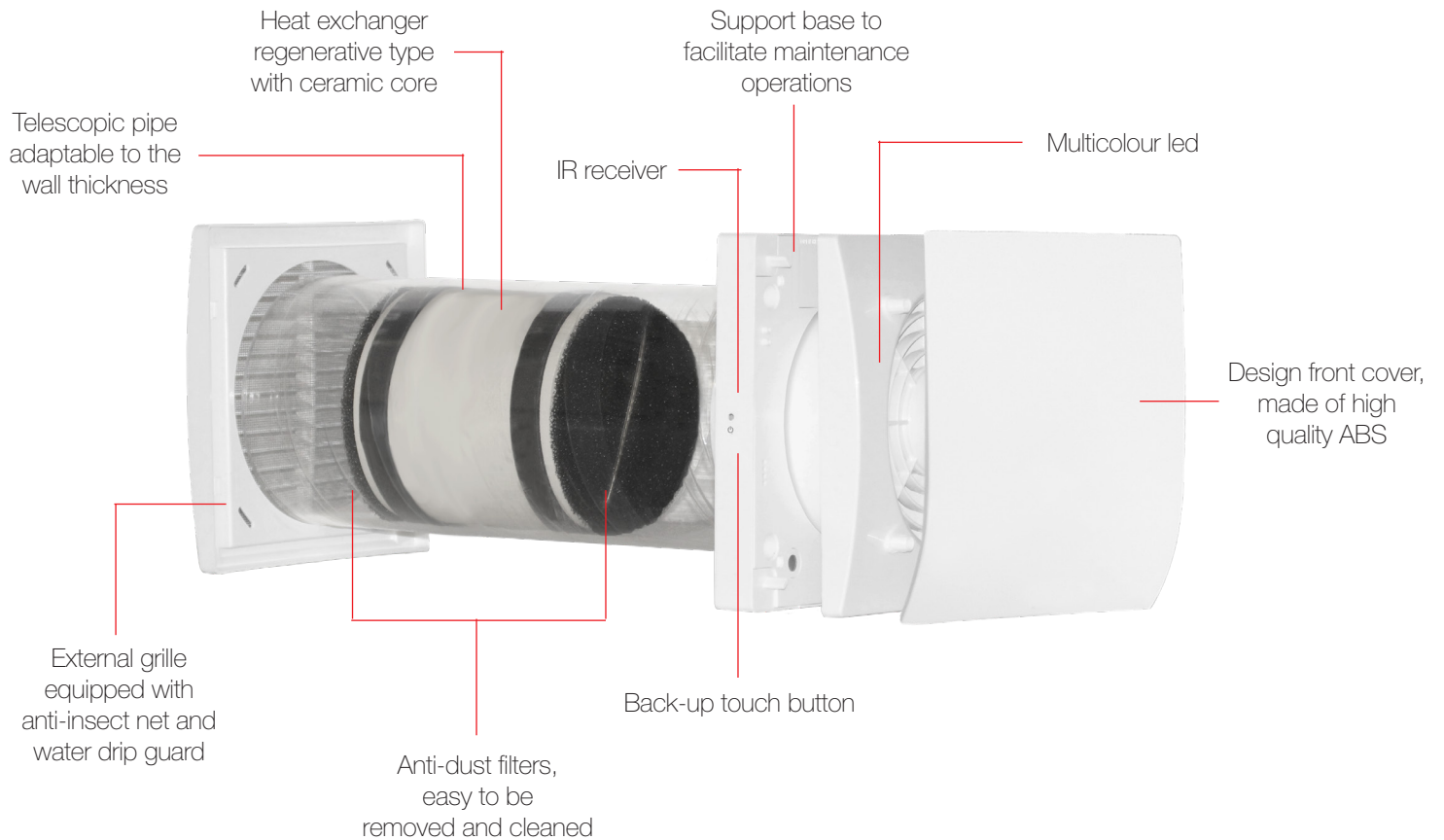

Functionalities selectable via IR remote control:

- air flow direction (alternate, extract only, intake only)
- free-cooling mode
- continuous speed (5 options)
- ON/OFF
- boost speed
- comfort/efficiency mode
- filters reset



Remote control and support base supplied